

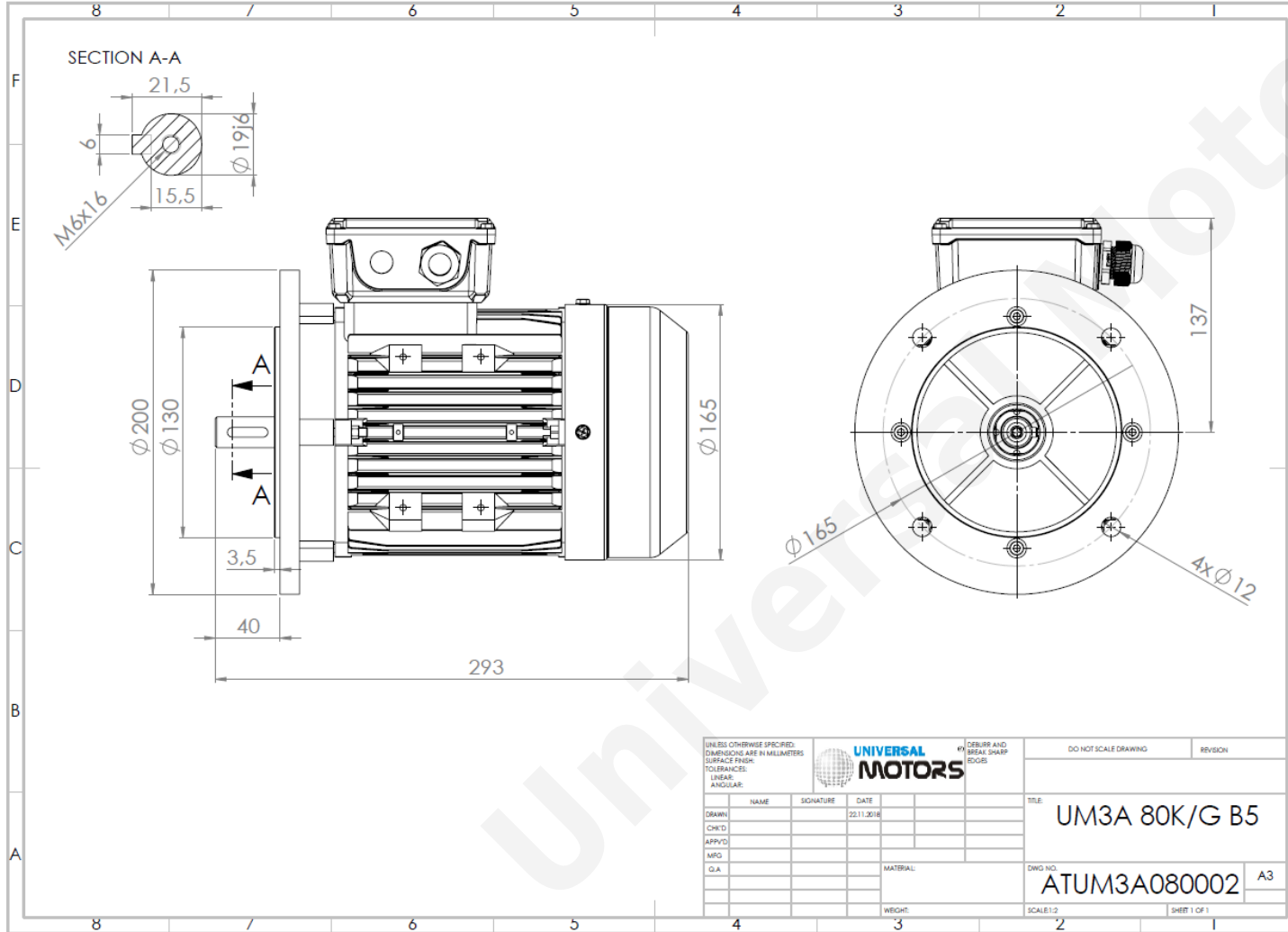

TECHNICAL DATA

Three Phase Electric Motors - Aluminum Frame
 PE31 80M2-2
 1.1 kW / 1.5 Cv
 2840 RPM



Motor type:	PE31 80M2-2
Output:	1.1 kW / 1.5 Cv
Speed (min ⁻¹):	2840 RPM
Frequency:	50 Hz
Voltage:	400 V
Current:	2.3 A
Power factor (Cos Ø):	0.83
Poles:	2
Insulation class:	F
Temperature rise Class:	B
Efficiency 50%:	80.6 %
Efficiency 75%:	81.5 %
Efficiency 100%:	82.7 %
Torque:	3.70 N.m
Tstarting/Tnominal:	2.3
Istarting/Inominal:	7.3
Tmaximum/Tnominal:	2.3
Noise:	74 Db(A)
Weight:	11 Kg
Bearing DE:	6204 2Z C3
Bearing NDE:	6204 2Z C3

UNLESS OTHERWISE SPECIFIED: DIMENSIONS ARE IN MILLIMETERS SURFACE FINISH:					DEBURR AND BREAK SHARP EDGES	DO NOT SCALE DRAWING	REVISION
TOLERANCES: LINEAR: ANGULAR:							
DRAWN	NAME	SIGNATURE	DATE	TITLE: UM3A 80K/G B5			
CHK'D			22.11.2018	DWG NO.:			
APPV'D				ATUM3A080002			
MFG				SCALE: 1:2			
Q.A.				SHEET 1 OF 1			
				MATERIAL:			
				WEIGHT:			

Regime - S1

Altitude - 1000m

Environment Temperature - 40°C

CONTACTS:

UNIVERSAL MOTORS Tel: +351 252 299 080
 Rua de São Brás,745 Fax: +351 252 299 089
 4480-782 VILA DO CONDE Mail: geral@universalmotors.pt

* References applied only in the UK